

2x2 or 2x4 LED Light Panel Installation Instructions



WARNING

- Risk of electrical shock or fire
- Verify power is off before installing or handling fixture
- This fixture is not suitable for damp, wet or hazardous locations
- Never handle the fixture with wet hands or while standing on wet/damp surfaces or in water

This fixture must be wired and installed in accordance with the National Electrical Code and all applicable local codes and requirements. Customers should consult a licensed electrician for installation requirements.

INSTALLATION

1. Place panel into vacant grid area.
2. Bend tabs into place. The hook should be over the top of the T-Bar. Reverse the tabs if your installation requires that the panel be screwed to the T-Bar system. Use a self tapping screws (not included) to pass through the tab and into the grid system.
3. Suspend the panel from the ceiling with approved wire. Holes are provided on the tabs

Bend tabs as shown to secure panel to the T-Bar system.

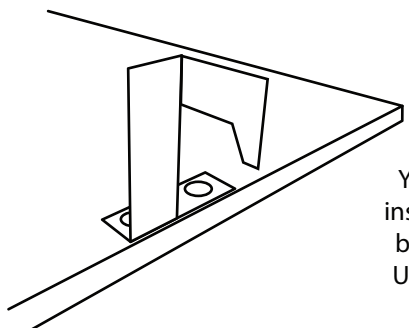
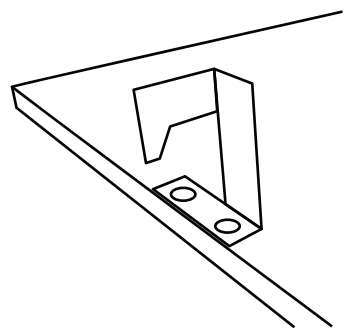

You can reverse the tabs if your installation requires the panel to be screwed to the T-Bar system. Use a self tapping screw to pass thru the tab and T-Bar.

ELECTRICAL CONNECTIONS

1. Secure LED into ceiling grid.
2. Shut off power to source for led panel.
3. Install panel and wire according to instructions below and in compliance with local rules and regulations.
4. Secure cover onto electrical box.
5. Restore power and check for correct operation.
6. The wall dimmer can dim up to 10 drivers when wired in parallel depending on distance and electromagnetic conditions.

